

HARDWARE USER MANUAL



- **WSL-1600-M12XB-24-67**

FCC Notice

This equipment has been tested and found to comply with the limits for a Class-A digital device, pursuant to Part 15 of the FCC rules. These limits are designed to provide reasonable protection against harmful interference in a residential installation. This equipment generates, uses, and can radiate radio frequency energy. It may cause harmful interference to radio communications if the equipment is not installed and used in accordance with the instructions. However, there is no guarantee that interference will not occur in a particular installation. If this equipment does cause harmful interference to radio or television reception, which can be determined by turning the equipment off and on, the user is encouraged to try to correct the interference by one or more of the following measures:

- Reorient or relocate the receiving antenna.
- Increase the separation between the equipment and receiver.
- Connect the equipment into an outlet on a circuit different from that to which the receiver is connected.
- Consult the dealer or an experienced radio/TV technician for help.

Caution: Any changes or modifications not expressly approved by the grantee of this device could void the user's authority to operate the equipment.

Déclaration FCC

Cet équipement a été testé et reconnu conforme aux limites de la classe A pour les équipements numériques, conformément à la section 15 des Réglementations FCC. Ces limites sont conçues pour fournir une protection raisonnable contre toutes interférences nuisibles dans un milieu résidentiel. Cet équipement génère, utilise, et peut émettre de l'énergie de fréquence radio et, s'il n'est pas installé et utilisé conformément au manuel d'instruction, peut perturber la réception radio. Cependant, il n'est pas garanti que l'équipement ne produira aucune interférence dans une installation particulière. Si cet équipement cause des interférences nuisibles à la réception radio ou télévisée, qui peuvent être déterminées en l'éteignant et le rallumant, l'utilisateur est encouragé à essayer de remédier au problème en prenant les mesures suivantes:

- Réorienter ou déplacer l'antenne réceptrice.
- Augmenter la distance entre l'équipement et le récepteur.
- Connecter l'équipement à une prise secteur sur un circuit différent de celui utilisé par le récepteur.
- Consulter le négociant ou un technicien radio/TV expérimenté.

Attention: Tout changement ou modification non expressément approuvé par le concessionnaire de cet appareil pourrait annuler l'autorité de l'utilisateur à utiliser l'équipement.

CE Mark Warning

This is a Class-A product. In a domestic environment this product may cause radio interference in which case the user may be required to take adequate measures.

CE Mark Avertissement

Ceci est un produit de classe A. Dans un environnement domestique, ce produit peut être utilisé en présence d'interférences radio.

This document is the current official release manual. Please check our website (www.wavesysglobal.com) for any updated manual or contact us by e-mail (sales.apac@wavesysglobal.com).

CONTENT

OVERVIEW	1
Key Features	1
Package Contents	2
Safety Precaution.....	2
HARDWARE DESCRIPTION	3
Physical Dimensions	3
Front Panel.....	4
LED Indicators.....	5
Ethernet Ports	6
USB Port	7
Console Port.....	7
Power Inputs	8
Relay Contact and Digital Input.....	9
Grounding Note	11
Bypass Function	11
Reset to Default.....	11
MOUNTING INSTALLATION	12
Wall Mounting.....	12
HARDWARE INSTALLATION.....	13
Installation Steps	13
TROUBLE SHOOTING	15

OVERVIEW

This series is rated IP67 and installation by Wall Mounting. Each unit of this industrial gigabit managed Ethernet switch provided 16*10/100/1000Base-Tx with IEEE 802.3at compliant ports (30W/port), suitable for Ethernet conversion applications.

In order to prevent unregulated voltage, this series provides high EFT and ESD protection. This also allows it to function in harsh environments, as well as support power redundancy with a dual power input design with reverse polarity protection.

With one model having an operating temperature of -10°C ~ 65°C, and another with a wide operating temperature of -40°C ~ 70°C, this series is designed to meet any needs for industrial automation application and harsh environments.

Key Features

Interface & Performance

- Copper port support auto MDI/MDI-X function
- Embedded 16*10/100/1000Base-T(X) with PoE-PSE (30W/Port)
- Store-and-forward switching architecture
- 32K MAC Address Table
- Supports 9.6Kbytes Jumbo Frame
- 32Mbits memory buffer

Power Input

- Dual 24-110VDC redundant power inputs through M12 5-Pin K-Coded male connector, with SELV output certified by UL61010-2-201
- Max. current 7A
- Max. PoE output: 120W

Certification

- CE/FCC

Operating Temperature

- Standard operating temperature model: -10°C ~ 65°C
- Extended operating temperature model (-T): -40°C ~ 70°C

Case/Installation

- IP67 protection
- Wall mount design
- Installation in a pollution degree 2 industrial environment
- Aluminum case

Package Contents

- 1 - WSL-1600-M12XB-24-67 - Unit weight: 4.268 kg (9.41 lb), Shipping weight: 4.992 kg (11.01 lb)
- 1 - M12 Protective Cap Set
- 1 - Quick installation guide

Safety Precaution

Attention

If the DC voltage is supplied by an external circuit, please use a protection device on the power supply input. Supply by UL Listed industrial use power. The industrial Ethernet switch's hardware specs, ports, cabling information, and wiring installation will be described within this user manual.

Attention

Si la tension CC est fournie par un circuit externe, veuillez utiliser un dispositif de protection sur l'entrée d'alimentation. Fourniture par courant industriel homologué UL. Les spécifications matérielles, les ports, les informations de câblage et l'installation du câblage du convertisseur de média industriel seront décrits dans ce manuel d'utilisation.

Warning Labels

The caution label means that you should check the certain information on user manual when working with the device. (Shown in *Figure 1.1*)

Étiquettes d'avertissement

L'étiquette d'avertissement signifie que vous devez vérifier certaines informations sur le manuel d'utilisation lorsque vous travaillez avec l'appareil. (Montré dans la *Figure 1.2*)



Figure 1.1 - Caution Label
Figure 1.1 - Étiquette de mise en garde



Figure 1.2 - Hot Surface Warning Label
Figure 1.2 - Étiquette d'avertissement de surface chaude

HARDWARE DESCRIPTION

Physical Dimensions

Figure 2.1, below, shows the physical dimensions of WSL-1600-M12XB-24-67 series.

(W x H x D) is 295mm x 160mm x 101.3mm

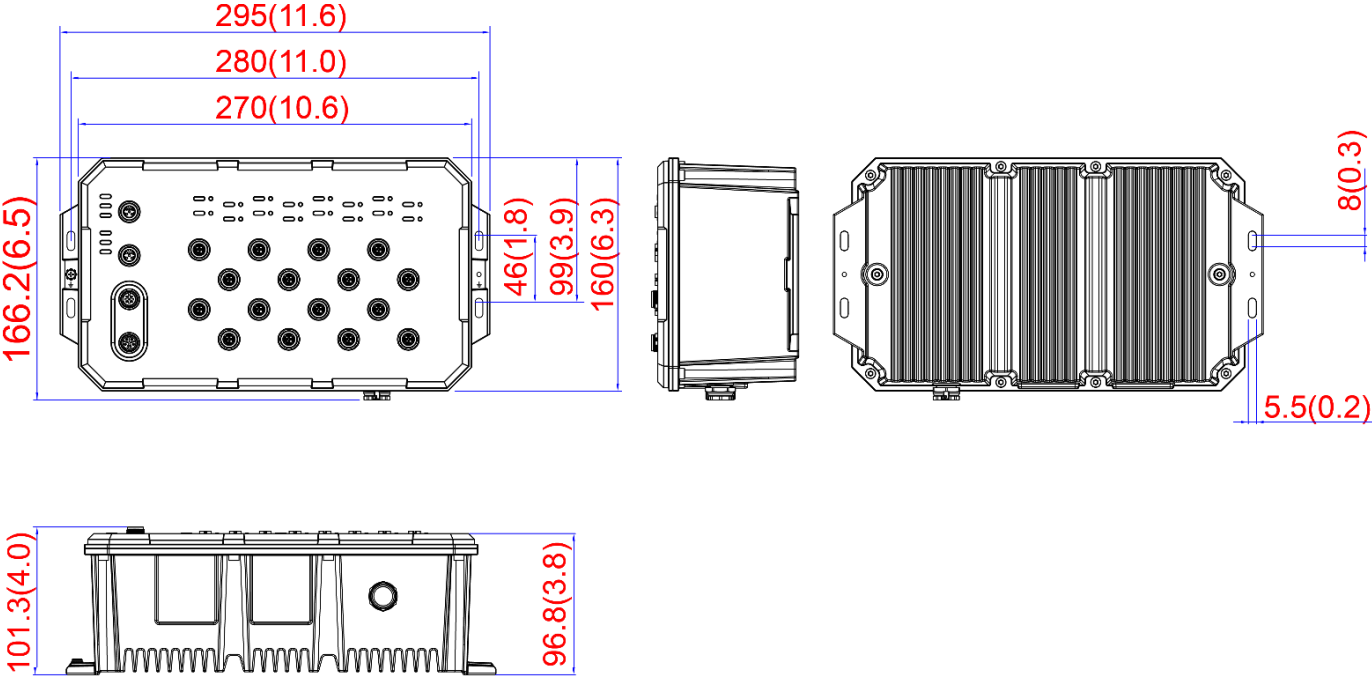

Unit: mm (inch)

Figure 2.1: Physical Dimensions

Front Panel

The front panel of the WSL-1600-M12XB-24-67 series industrial PoE+ gigabit Managed Ethernet Switch is shown below in Figure 2.2. On the front panel, it provides 16 M12 connectors in a polka dot pattern to ensure easier plugging and safer operation. The LED indicates various status by different colors and shapes of the light. Besides, this series supports console, USB, DI/DO and dual DC power inputs (24-110VDC) with M12 type connectors.

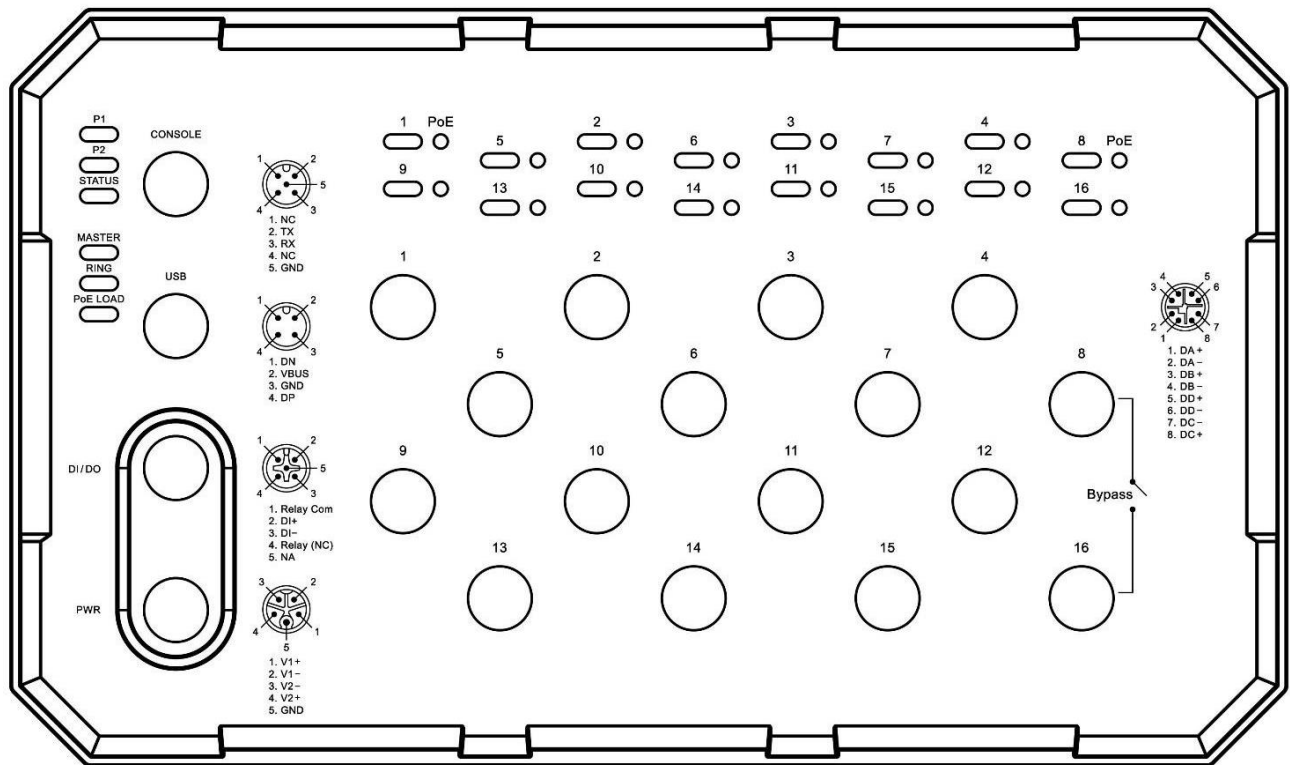

Figure 2.2: The Front Panel

LED Indicators

There are LED light indicators located on the front panel of the industrial switch that display the power status and network status. Each LED indicator has a different color and has its own specific meaning, see below in Table 2.1.

LED	Color	Description	
P1	Green	On	Power input 1 is active
		Off	Power input 1 is inactive
P2	Green	On	Power input 2 is active
		Off	Power input 2 is inactive
Status	Green	On	No event happened after the last reset or reboot
	Red	On	1. System booting 2. Event happened by software setting
	Red	Flashing	Firmware Upgrade
Master	Green	On	ERPS Owner Mode (Ring Master) is ready
		Off	ERPS Owner Mode is not active
Ring	Green	On	ERPS Ring Network is active and work well
		Flashing	ERPS Ring works abnormally or misconfigure
		Off	ERPS Ring Network is not active
PoE Load	-	Off	The current overall PoE output power divided by power budget is $\leq 50\%$
	Blue	On	The current overall PoE output power divided by power budget is $51\% \sim 70\%$
	Red	On	The current overall PoE output power divided by power budget is $71\% \sim 90\%$
	Red	Flashing	The current overall PoE output power divided by power budget is $91\% \sim 100\%$
L/A Port 01-16	Green	On	Connected to the network with 1000Mbps
		Flashing	Networking is active
		Off	Not connected to network
	Amber	On	Connected to the network with 10/100Mbps
		Flashing	Networking is active
		Off	Not connected to network
PoE	Amber	On	Supplying power to the powered-device
		Off	Not connected to a Powered Device

Table 2.1: LED Indicators

Ethernet Ports

M12 Interface (Auto MDI/MDIX)

- Connection Format: M12 8-Pin X-Coded Female Connector
- Transmission rate: 10/100/1000 Mbit/s

Prepare the M12 8-Pin X-Coded Ethernet Port mating cable for Ethernet connection. The M12 X-Coded Ethernet ports are auto-sensing for 10Base-T, 100Base-TX, or 1000Base-T devices connections. Auto MDI/MDIX means that you can connect to another switch or workstation without changing straight through or crossover cabling. See pin assignment shown in Table 2.2

M12 8-Pin X-Coded Female Connector			
	Pinouts	10/100Base-T(X) Signal	1000Base-T Signal
	1	Transmit Data + (TX+)	BI_DA+
	2	Transmit Data - (TX-)	BI_DA-
	3	Receive Data + (RX+)	BI_DB+
	4	Receive Data - (RX-)	BI_DB-
	5		BI_DD+
	6		BI_DD-
	7		BI_DC-
	8		BI_DC+

Table 2.2

Note: “+” and “-” signs represent the polarity of the wires that make up each wire pair.

Connection of Cables

Use the twisted-pair cable, category 5e or the above cabling for M12 port connections. The cable between the Ethernet switch and the link partner (switch, hub, workstation, etc.) must be less than 100 meters (328 ft.) long.

- Minimum Wire Gauge: 24AWG
- Maximum Transmission Length: 100m (328ft)



Caution: Please use with copper conductors only

Attention: DESTINÉ À ÊTRE UTILISÉ AVEC DES CONDUCTEURS EN CUIVRE SEULEMENT



Caution: Use conductors with insulation rated for at least 60°C

Attention: AVERTISSEMENT: EMPLOYER DES CONDUCTEURS POUR AU MOINS 60°C



Caution: Base the conductor Ampacity on a maximum termination temperature of 60°C

Attention: LE COURANT ADMISSIBLE DU CONDUCTEUR DOIT ÊTRE DÉTERMINÉ EN FONCTION D'UNE TEMPÉRATURE MAXIMALE AUX TERMINAISONS DE 60°C

USB Port

- It is a M12 4-Pin A-Coded female connector
- USB Port is for configuration backup / restore
- M12 connector

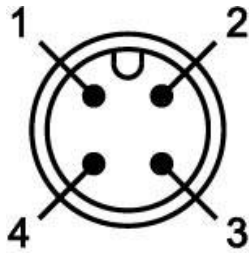
M12 4-Pin A-Coded female Connector		
	Pinouts	Function
	1	DN
	2	VBUS
	3	GND
	4	DP

Console Port

- It is a M12 5-Pin A-Coded female connector
- Baud rate 115,200bps, 8, N, 1
- M12 connector

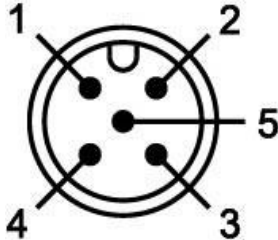
M12 5-Pin A-Coded female Connector		
	Pinouts	Function
	1	NC
	2	TX
	3	RX
	4	NC
	5	GND

Power Inputs

This industrial Ethernet switch provides dual DC power inputs for redundancy through M12 5-pin K-Coded male connector. Prepare the M12 5-pin K-Coded cable for power connection. Table 2.3 shows the pin assignment.

M12 5-Pin K-Coded Male Connector		
	Pinouts	Function
	1	V1+
	2	V1-
	3	V2-
	4	V2+
	5	GND

Table 2.3

Connection of Cables

- Minimum Wire Gauge: 18AWG

Please follow the below steps to insert the power wire.

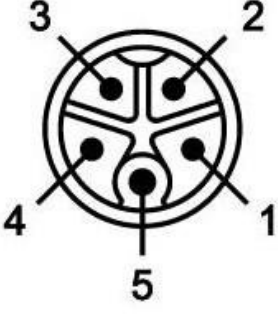
Step 1. Insert the positive and negative power wires into the power connector on the industrial Ethernet switch with Power 1 (V1+, V1-), and Power 2 (V2+, V2-).

Step 2. Tighten the screw nut to prevent the connector from loosening.

Relay Contact and Digital Input

The Ethernet switch is equipped a M12 5-Pin A-Coded male connector with a normally closed relay contact for fault alarm and a digital input (DI). The pin assignment of this connector is shown in Table 2.4.

M12 5-Pin A-Coded Male Connector			
	Pinouts	Function	Description
	1	DI+ Relay Com	Common
	2	DI+	Digital Input +
	3	DI-	Digital Input -
	4	DI- Relay (N.C.)	Normally Closed
	5	NA	Not Assigned

Table 2.4

Connection of Cables

- Minimum Wire Gauge: 24AWG

Relay Contact

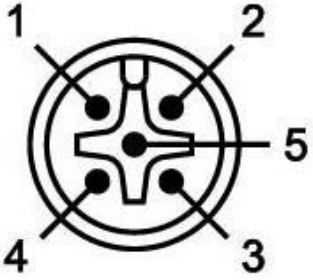
Relay is opened if any event listed below happens

1. The current PoE outputs of all connected PDs exceed 240 Watts (for PoE models)
2. Power 1 or Power 2 was inactive
3. If any one of all PoE ports exceeds 30Watts (for PoE models)
4. Event happened by software setting

Relay is closed under the conditions below

1. No event after reboot
2. No event after reset the switch

A connection of relay contact for fault alarm is shown below in Figure 2.3.

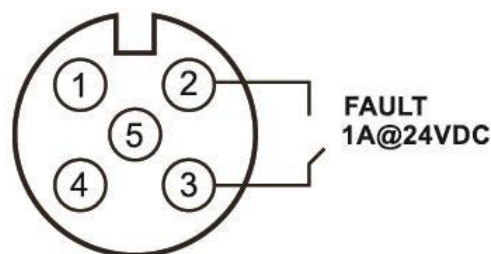

Figure 2.3: Wiring the relay contact for fault alarm

When the Ethernet switch is operating normally, the relay contact is a closed circuit. When the switch has any fault status (PoE overload or power failure), the relay contact circuit is opened and the FAULT LED lights up. In addition, even after even after the abnormal situation has been removed, the relay contact is still open and FAULT LED remains active, unless using the digital input to reset that. See the next section for information on Digital Input.

Digital Input (DI)

The digital input is used for monitoring two external events via an external voltage source. When the voltage level on digital input pins changes from high voltage to low voltage, the DI function will be triggered. Table 2.5 is shown a detail specification of the digital input.

Specification		Description
Level 0 (Low)	-30~8VDC	Will trigger DI function (active trigger states)
Level 1 (High)	10~30VDC	Normal Status (inactive trigger states)
Nominal input voltage	24VDC	
Max. input voltage	30VDC	
Nominal input current	5mA (typical)	
Max. input current	8mA	

Table 2.5: Specification of DI

Grounding Note

Grounding and wire routing help limit the effects of noise due to electromagnetic interference (EMI). Run the ground connection from the ground screw to the grounding surface prior to connecting devices. The grounding screw symbol is shown below in Figure 2.5.

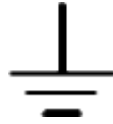

Figure 2.5: Grounding screw symbol



Caution: Using a shielded cable achieves better electromagnetic compatibility.



Attention: L'utilisation d'un câble blindé permet une meilleure compatibilité électromagnétique.

Bypass Function

This Ethernet switch supports bypass function by two Ethernet ports (P8 and P16). When one of the Ethernet switches loses power, Ethernet ports (P8 and P16) will bypass the power lost Ethernet switch to prevent the network from disconnecting.

Take Figure 2.5 for example, if Switch B has power failure, the bypass function will be activated automatically, and it will bypass Switch B and bridge P8 to P16 of Switch B, so that the data transmission path (from Switch A to C) can remain connected and unaffected.

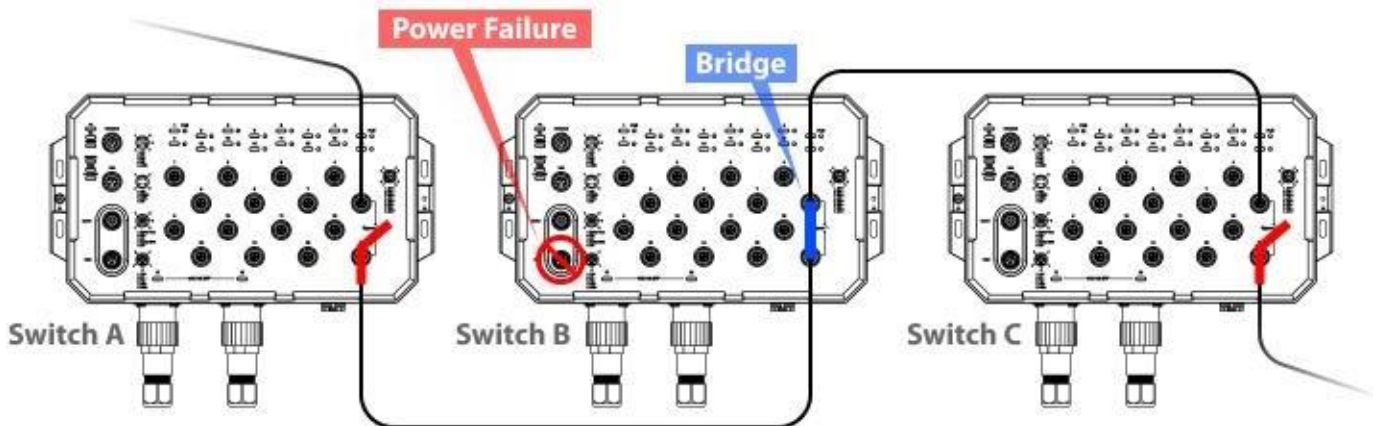

Figure 2.5: Example of bypass function

Reset to Default

Please perform the below steps to reset the switch to factory default setting.

- Step 1. Reverse the Tx & Rx of the Console Cable and plug it into the console port.
- Step 2. Restart the power.
- Step 3. The switch will start rebooting with the port LEDs flashing.
- Step 4. When the Status LED turns into Green, the process is completed.
- Step 5. Remove the reversed console cable.

MOUNTING INSTALLATION

Wall Mounting

Follow the steps below to mount the industrial Ethernet switch to a wall using the screw holes as shown below in Figure 3.1.

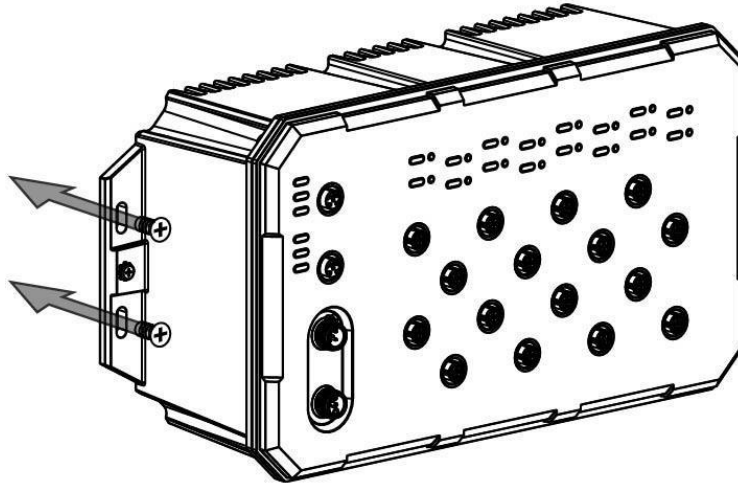

Figure 3.1: The Rear Side of the Switch

Follow the steps below to learn how to hang the industrial Switch.

Step 1. Prepare 4 screws for mounting the switch to a wall.

Note: Recommended use the M5 screws.

Step 2. Based on the Figure 3.2: Physical Dimensions which is shown the positions of 4 screw holes on the left and right side of the switch to make 4 screw holes on a wall accordingly.

Step 3. Insert the screws through the screw holes on the switch and screw the switch into the wall. Shown above in Figure 3.1.

Step 4. To remove the switch from the wall, do the opposite from the steps above.

Note: Make sure disconnect all cables from the switch before removing the unit from the wall.

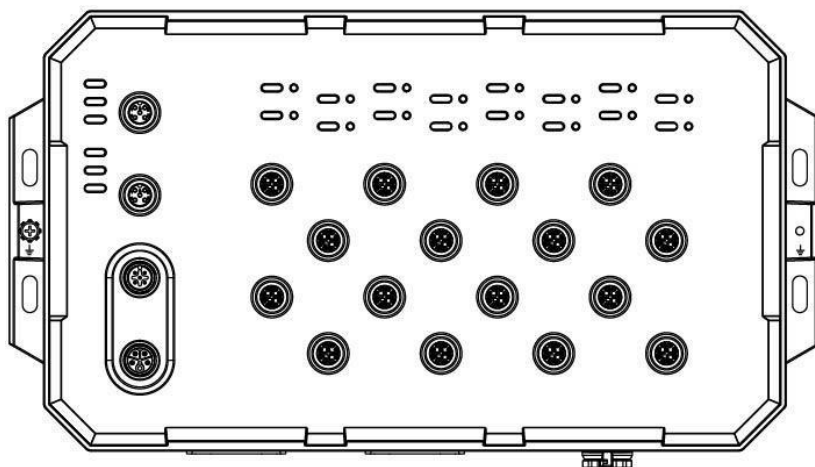

Figure 3.2: Position of the screw holes

HARDWARE INSTALLATION

Installation Steps

This section will explain how to install WSL-1600-M12XB-24-67 series.

Installation Steps

Step 1. Unpack the industrial Ethernet switch from the original packing box.

Step 2. To hang the industrial Ethernet switch on a wall, please refer to the Mounting Installation section.

Step 3. Power on the industrial Ethernet switch and then the power LED light will turn on.

- If you need help on how to wire power, please refer to the **Power Inputs** section.
- Please refer to the **LED Indicators** section for LED light indication.

Step 4. Prepare the M12 cable for Ethernet connection.

Step 5. Insert one side of the M12 cable into switch's Ethernet port and on the other side into the networking device's Ethernet port. The Ethernet port's (L/A) LED on the industrial Ethernet switch will turn on when the cable is connected to the networking device.

- Please refer to the **LED Indicators** section for LED light indication.

Step 6. When all connections are set and the LED lights all show normal, the installation is complete.



Caution: If the equipment is used in a manner not specified by the manufacturer, the protection provided by the equipment may be impaired.



Attention: Si l'équipement est utilisé d'une manière non spécifiée par le fabricant, la protection fournie par l'équipement peut être altérée.



Caution: The installation that the safety to any system incorporating the equipment is the responsibility of the assembler of the system.



Attention: L'installation que la sécurité de tout système intégrant l'équipement est de la responsabilité de l'assembleur du système.



Caution: This is an OPEN TYPE module and should be installed in a final safety enclosure characteristic.



Attention: Il s'agit d'un module de TYPE OUVERT et doit être installé dans une caractéristique finale d'enceinte de sécurité.



Caution: This device is intended for use indoor and at altitudes up to 2000 meters.



Attention: Cet appareil est destiné à être utilisé en intérieur et à des altitudes allant jusqu'à 2000 mètres.



Caution: Ambient Relative Humidity should be within the range of 5 and 95% (non-condensing).



Attention: L'humidité relative ambiante doit être comprise entre 5 et 95% (sans condensation).

TROUBLE SHOOTING

- Verify you have the right power cord or adapter. Never use a power supply or adapter with a non-compliant DC output voltage or it will burn the equipment.
- Select the proper UTP or STP cable in order to construct the network. Use an unshielded twisted-pair (UTP) or shield twisted-pair (STP) cable for RJ-45 connections: 100Ω Category 5e for 10M/100/1000Mbps. Also be sure that the length of any twisted-pair connection does not exceed 100 meters (328 feet).
- Diagnosing LED Indicators: To assist in identifying problems, the Switch can be easily monitored with the LED indicators which help to identify if any problems exist.
- ◆ Please refer to the LED Indicators section for LED light indication.
- If the power indicator LED does not turn on when the power cord is plugged in, the user may have a problem with the power cord. Check for loose power connections, power losses or surges at the power outlet.
- ◆ Please contact Wavesys for technical support service, if the problem still cannot be resolved.
- If the industrial Switch LED indicators are normal and the connected cables are correct but the packets still cannot transmit, please check the system's Ethernet devices' configuration or status.