

# HARDWARE USER MANUAL

---



- WINJ-0201-90W-T

## FCC Notice

This equipment has been tested and found to comply with the limits for a Class-A digital device, pursuant to Part 15 of the FCC rules. These limits are designed to provide reasonable protection against harmful interference in a residential installation. This equipment generates, uses, and can radiate radio frequency energy. It may cause harmful interference to radio communications if the equipment is not installed and used in accordance with the instructions. However, there is no guarantee that interference will not occur in a particular installation. If this equipment does cause harmful interference to radio or television reception, which can be determined by turning the equipment off and on, the user is encouraged to try to correct the interference by one or more of the following measures:

- Reorient or relocate the receiving antenna.
- Increase the separation between the equipment and receiver.
- Connect the equipment into an outlet on a circuit different from that to which the receiver is connected.
- Consult the dealer or an experienced radio/TV technician for help.

**Caution: Any changes or modifications not expressly approved by the grantee of this device could void the user's authority to operate the equipment.**

## Déclaration FCC

Cet équipement a été testé et reconnu conforme aux limites de la classe A pour les équipements numériques, conformément à la section 15 des Réglementations FCC. Ces limites sont conçues pour fournir une protection raisonnable contre toutes interférences nuisibles dans un milieu résidentiel. Cet équipement génère, utilise, et peut émettre de l'énergie de fréquence radio et, s'il n'est pas installé et utilisé conformément au manuel d'instruction, peut perturber la réception radio. Cependant, il n'est pas garanti que l'équipement ne produira aucune interférence dans une installation particulière. Si cet équipement cause des interférences nuisibles à la réception radio ou télévisée, qui peuvent être déterminées en l'éteignant et le rallumant, l'utilisateur est encouragé à essayer de remédier au problème en prenant les mesures suivantes:

- Réorienter ou déplacer l'antenne réceptrice.
- Augmenter la distance entre l'équipement et le récepteur.
- Connecter l'équipement à une prise secteur sur un circuit différent de celui utilisé par le récepteur.
- Consulter le négociant ou un technicien radio/TV expérimenté.

**Attention: Tout changement ou modification non expressément approuvé par le concessionnaire de cet appareil pourrait annuler l'autorité de l'utilisateur à utiliser l'équipement.**

## CE Mark Warning

This is a Class-A product. In a domestic environment this product may cause radio interference in which case the user may be required to take adequate measures.

## CE Mark Avertissement

Ceci est un produit de classe A. Dans un environnement domestique, ce produit peut être utilisé en présence d'interférences radio.

This document is the current official release manual. Please check our website ([www.wavesysglobal.com](http://www.wavesysglobal.com)) for any updated manual or contact us by e-mail ([sales.apac@wavesysglobal.com](mailto:sales.apac@wavesysglobal.com)).

# CONTENT

<b>OVERVIEW .....</b>	<b>1</b>
Key Features .....	1
Package Contents .....	2
Safety Precaution.....	2
<b>HARDWARE DESCRIPTION .....</b>	<b>3</b>
Physical Dimensions .....	3
Front Panel.....	4
Top View.....	4
LED Indicators.....	5
Relay Contact Alarm Warning .....	5
Ethernet Ports .....	6
Cabling.....	7
Wiring the Power Inputs.....	7
Wiring the Fault Alarm Contact .....	8
Grounding Note .....	8
<b>MOUNTING INSTALLATION .....</b>	<b>9</b>
DIN-Rail Mounting .....	9
Wall Mounting.....	11
<b>HARDWARE INSTALLATION.....</b>	<b>12</b>
Installation Steps .....	12
<b>TROUBLE SHOOTING .....</b>	<b>14</b>

# OVERVIEW

PoE and Non-PoE are both highly utilized in industrial networking applications nowadays; however, it sometimes goes to an awkward situation that end-device, e.g. remote camera, supports PoE function but the Ethernet switch does not. Is there any other solution but replacing the switch with a PoE one?

WINJ-0201-90W-T Series solve the problem simply by deploying data and power from non-PoE switch and power input to the PD device. PoE injector is a brilliant low-cost solution for the case that only one side of the device is supporting PoE function. Therefore WINJ-0201-90W-T Series will be your best choice to deal with the lack of PoE function cases.

Additionally, WINJ-0201-90W-T Series supports power input from 48VDC to 55VDC, ensuring full 90W PoE output, in compliance with IEEE 802.3bt standard for better usage in various industrial markets, like automation, surveillance, and vehicle industry. Besides that, with the fan-less design, this model series also works perfectly in polarized temperatures from -40~75°C and undoubtedly becomes your best option in a harsh environment.

## Key Features

### Interface & Performance

- Embedded 1\*10/100/1000Tx for LAN-In and 1\*10/100/1000Tx for BT PoE P.S.E. Out
- Compliant with IEEE802.3af/at/bt PoE technologies
- Support auto detection and classification for PoE application
- Support short-circuit and current-overloading protection for PoE application

### Power Input

- WINJ-0201-90W-T(-T): Dual 48-55VDC redundant power inputs
- 1\*4-pin removable terminal block
- Max. current 2A (Included PoE power budget)
- Max. PoE output: 90W

### Certification

- CE/FCC
- UL 61010-1
- UL 61010-2-201

### Operating Temperature

- Standard operating temperature model: -10°C ~ 65°C
- Extended operating temperature model (-T): -40°C ~ 75°C

### Case/Installation

- IP30 protection (not certified by UL)
- DIN-Rail and wall mount design
- Installation in a pollution degree 2 industrial environment
- Installation in the environment with adequate airflow
- Standalone Installation

## Package Contents

- 1 - WINJ-0201-90W-T(-T) - Unit weight: 0.35 kg (0.77 lbs.), Shipping weight: 0.498 kg (1.1 lbs.)
- 2 - Wall mounting brackets and screws
- 1 - Quick installation guide

## Safety Precaution

### Attention

If the DC voltage is supplied by an external circuit, please use a protection device on the power supply input. Supply by UL Listed industrial use power. The industrial Ethernet injector's hardware specs, ports, cabling information, and wiring installation will be described within this user manual.

### Attention

Si la tension CC est fournie par un circuit externe, veuillez utiliser un dispositif de protection sur l'entrée d'alimentation. Fourniture par courant industriel homologué UL. Les spécifications matérielles, les ports, les informations de câblage et l'installation du câblage du convertisseur de média industriel seront décrits dans ce manuel d'utilisation.

### Warning Labels

The caution label means that you should check the certain information on user manual when working with the device. (Shown in *Figure 1.1*)

### Étiquettes d'avertissement

L'étiquette d'avertissement signifie que vous devez vérifier certaines informations sur le manuel d'utilisation lorsque vous travaillez avec l'appareil. (Montré dans la *Figure 1.2*)



Figure 1.1 - Caution Label  
Figure 1.1 - Étiquette de mise en garde



Figure 1.2 - Hot Surface Warning Label  
Figure 1.2 - Étiquette d'avertissement de surface chaude

# HARDWARE DESCRIPTION

## Physical Dimensions

Figure 2.1, below, shows the physical dimensions of WINJ-0201-90W-T Series.

(W x H x D) is 30mm x 95mm x 75mm

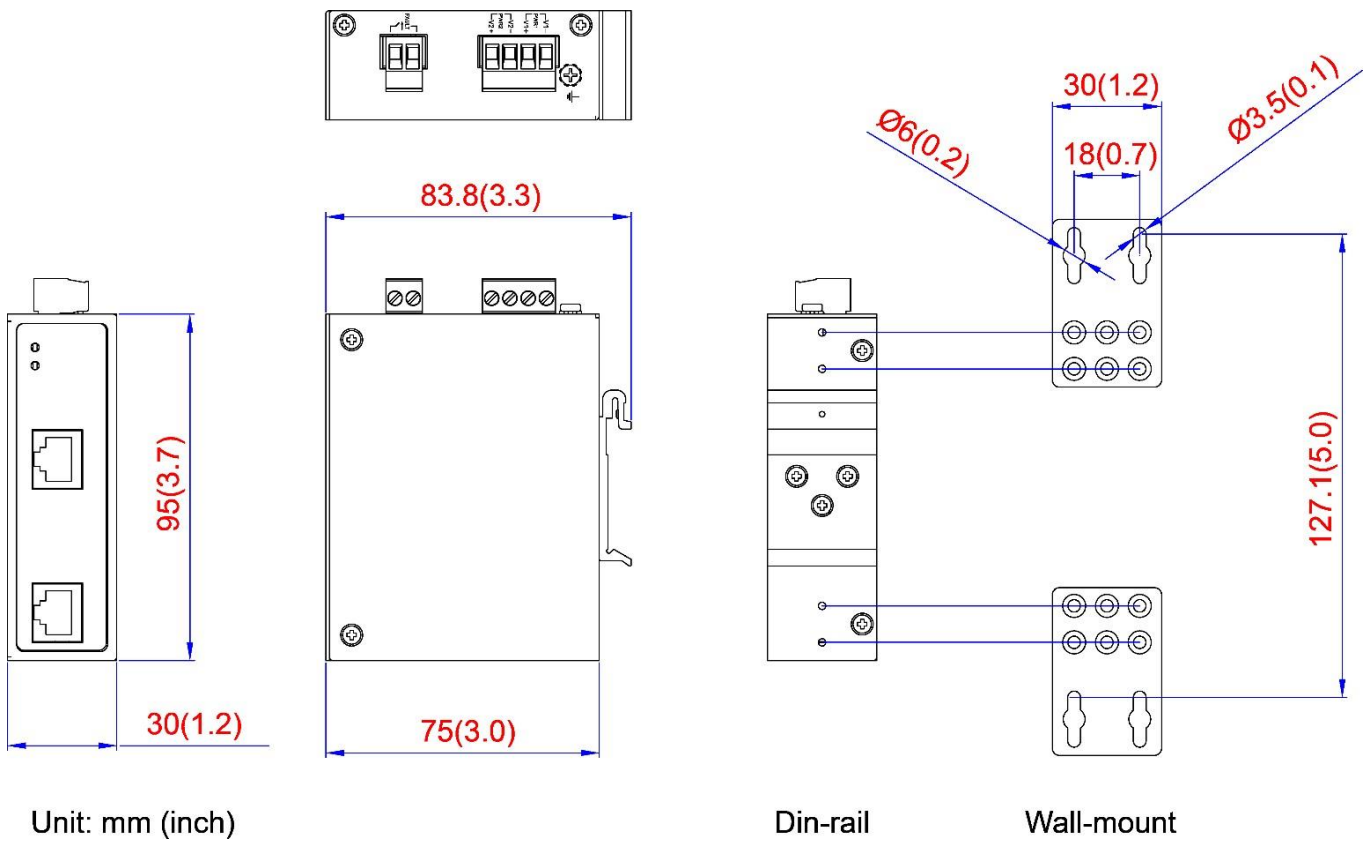

Figure 2.1: Physical Dimensions

## Front Panel

The front panel of the WINJ-0201-90W-T Series Industrial Gigabit BT-PoE Injector is shown below in Figure 2.2.

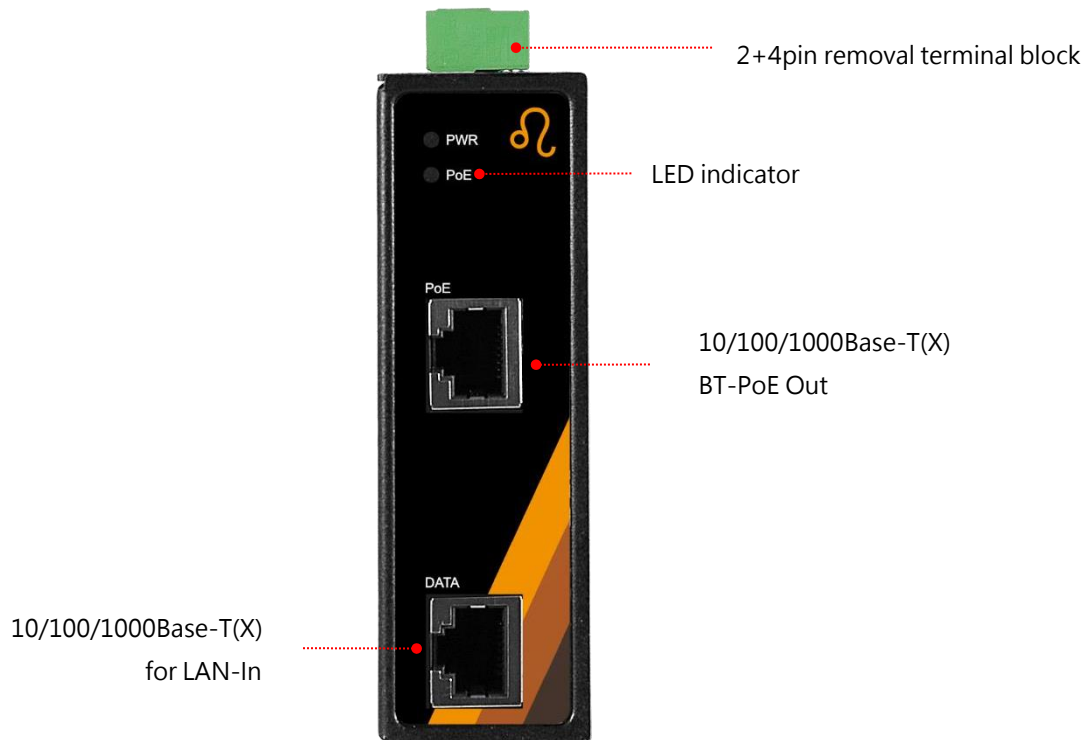

Figure 2.2: The Front Panel

## Top View

Figure 2.3, below shows the top panel of the WINJ-0201-90W-T Series Industrial Gigabit BT-PoE Injector that is equipped with one 2-pin terminal block for relay contact alarm and 4-pin terminal block connectors for dual DC power inputs (48-55VDC).

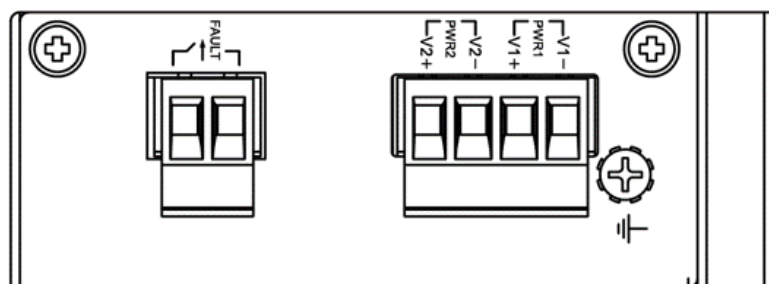

Figure 2.3: Top Panel View

## LED Indicators

There are LED light indicators located on the front panel of the industrial switch that display the power status and network status. Each LED indicator has a different color and has its own specific meaning, see below in Table 2.1.

LED	Color	Description	
PWR	Green	On	Power input 1 and 2 are active
	Red	On	Power input 1 or 2 is inactive, trigger relay
	-	Off	Power input 1 and 2 is inactive
PoE	Amber	On	The PoE output port is supplying power to the powered-device over <b>2 pairs</b>
	Green	On	The PoE output port is supplying power to the powered-device over <b>4 pairs</b>
	-	Off	No powered-device attached or power supplying fails

Table 2.1: LED Indicators

## Relay Contact Alarm Warning

The relay contact alarm supports power redundancy failed, PoE total output watts >100% warning and PoE over current or cable short warning. There are 5 key trigger events, please follow the below rules:

The relay contact alarm will be triggered when anyone of the listed events occurs.

Key trigger event 1: Power-1 or Power-2 is inactive

Key trigger event 2: PoE total loading >100% PoE output budget

Key trigger event 3: PoE over current per port

Key trigger event 4: Cable short per port

Key trigger event 5: One of the channels in Dual PD fail

[Notice] When the relay is triggered because of Event 2~5, the relay contact alarm, will update the status every 30 seconds. If there is no event happening for 30 seconds, the relay contact alarm will be turn off. If the user disables the failed PoE port by removing the cable or Dip Switch manually, the relay will be recovered immediately.



## Ethernet Ports

### RJ-45 Ports (Auto MDI/MDIX)

The RJ-45 ports are auto-sensing for 10Base-T, 100Base-TX or 1000Base-T devices connections. Auto MDI/MDIX means that the unit can connect to another one or workstation without changing the straight-through or crossover cabling. See the figures as below for straight-through and crossover cabling schematics.

1 2 3 4 5 6 7 8

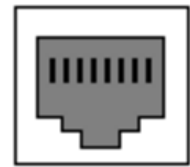

RJ-45 Female

### 10/100BASE-T(X) RJ-45 Pin Assignments (Table 2.2)

Crossover Cable		Straight Through Cable	
Pin Number / Signal	Pin Number / Signal	Pin Number / Signal	Pin Number / Signal
1 / RX+	3 / TX+	1 / RX+	1 / TX+
2 / RX-	6 / TX-	2 / RX-	2 / TX-
3 / TX+	1 / RX+	3 / TX+	3 / RX+
6 / TX-	2 / RX-	6 / TX-	6 / RX-

Table 2.2

### 1000BASE-T RJ-45 Pin Assignments (Table 2.3)

Crossover Cable		Straight Through Cable	
Pin Number / Signal	Pin Number / Signal	Pin Number / Signal	Pin Number / Signal
1 / TP0+	3 / TP1+	1 / TP0+	1 / TP1+
2 / TP0-	6 / TP1-	2 / TP0-	2 / TP1-
3 / TP1+	1 / TP0+	3 / TP1+	3 / TP0+
4 / TP2+	7 / TP3+	4 / TP2+	4 / TP3+
5 / TP2-	8 / TP3-	5 / TP2-	5 / TP3-
6 / TP1-	2 / TP0-	6 / TP1-	6 / TP0-
7 / TP3+	4 / TP2+	7 / TP3+	7 / TP2+
8 / TP3-	5 / TP2-	8 / TP3-	8 / TP2-

Table 2.3

**Note:** “+” and “-” signs represent the polarity of the wires that make up each wire pair.

## Cabling

Use the four twisted-pair, category 5e, or the above cabling for RJ-45 port connections. The total length from the device A through the injector to the device B must not exceed 100 meters.

## Wiring the Power Inputs



**Caution:** Please follow the below steps to insert the power wire.



**Attention:** Veuillez suivre les étapes ci-dessous pour insérer le câble d'alimentation.

Step 1 Insert the positive and negative wires into the PWR1 (V1+, V1-) and PWR2 (V2+, V2-) contacts on the terminal block connector as shown below in Figure 2.4.

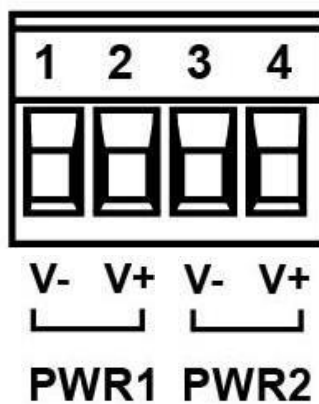

Figure 2.4: Power Terminal Block

Step 2 Tighten the wire-clamp screws to prevent the wires from loosening, as shown below in Figure 2.5.

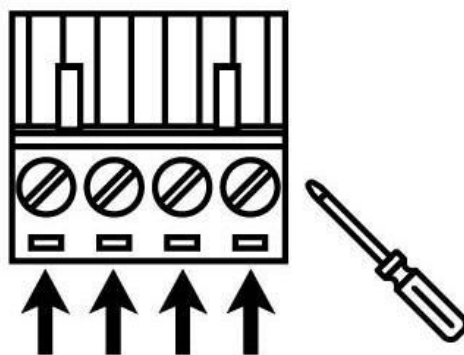

Figure 2.5: Power Terminal Block



**Caution:** Only use copper conductors, 125°C, tighten to 7 in-lbs (0.79 Nm). The wire gauge for the terminal block should range between 18~20 AWG.



**Attention:** Utilisez uniquement des conducteurs en cuivre, 125 ° C, serrer à 7 in-lbs (0,79 Nm). Le calibre des fils du bornier doit être compris entre 18 et 20 AWG.

## Wiring the Fault Alarm Contact

The fault alarm contact is on the 2-pin terminal block connector as the picture shown below. By inserting the wires, it will detect the fault status including power failure or port link failure (managed industrial switch only) and form a normally open circuit. An application example for the fault alarm contact is shown below in Figure 2.6.

Insert the wires into fault alarm contact

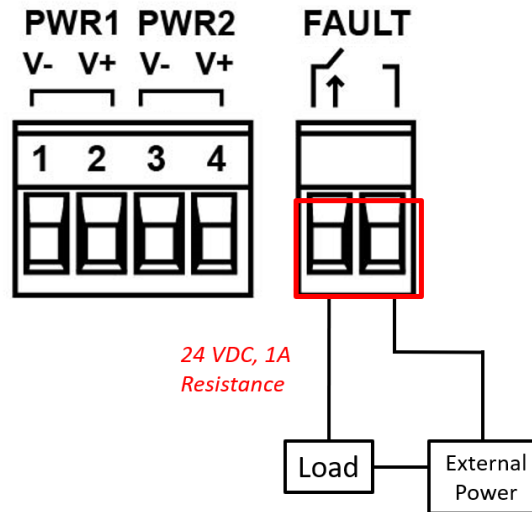

Figure 2.6: Fault Alarm Contact

## Grounding Note

Grounding and wire routing help limit the effects of noise due to electromagnetic interference (EMI). Run the ground connection from the ground screw to the grounding surface prior to connecting devices. The grounding screw symbol is shown below in Figure 2.7.

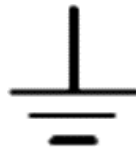

Figure 2.7: Grounding screw symbol



**Caution:** Using a shielded cable achieves better electromagnetic compatibility.



**Attention:** L'utilisation d'un câble blindé permet une meilleure compatibilité électromagnétique.

## MOUNTING INSTALLATION

### DIN-Rail Mounting

The DIN-Rail is pre-installed on the industrial Ethernet Injector from the factory. If the DIN-Rail is not on the unit, please see Figure 3.1 to learn how to install the DIN-Rail on it.



Figure 3.1: The Rear Side of the Injector and Wall Mounting Bracket

Follow the steps below to learn how to hang the industrial Ethernet injector.

Step 1. Use the screws to install the DIN-Rail bracket on the rear side of the industrial Ethernet injector.

Step 2. To remove the DIN-Rail bracket, do the opposite from Step 1.

Step 3. After the DIN-Rail bracket is installed on the rear side of the injector, insert the top of the DIN-Rail on to the track as shown below in Figure 3.2.

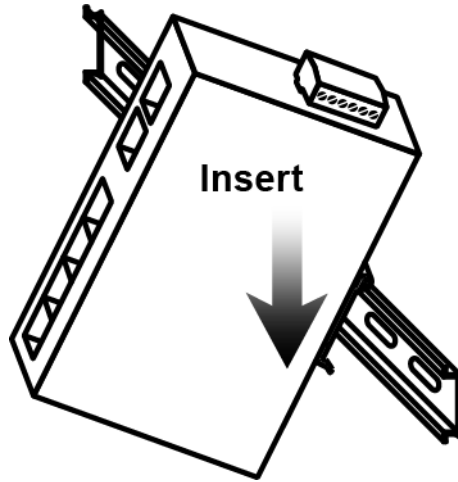

Figure 3.2: Insert the Injector on the DIN-Rail

Step 4. Lightly pull down the bracket on to the rail as shown below in Figure 3.3.

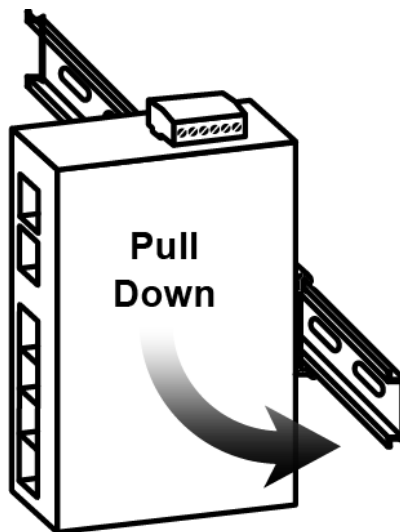

Figure 3.3: Stable the Injector on DIN-Rail

Step 5. Check if the bracket is mounted tightly on the rail.

Step 6. To remove the industrial Ethernet injector from the rail, do the opposite from the above steps.

## Wall Mounting

Follow the steps below to mount the industrial Ethernet injector using the wall mounting bracket as shown below in Figure 3.4.

Step 1. Remove the DIN-Rail bracket from the industrial Ethernet injector by loosening the screws.

Step 2. Place the wall mounting brackets on the top and bottom of the industrial Ethernet injector.

Step 3. Use the screws to screw the wall mounting bracket on the industrial Ethernet injector.

Step 4. Use the hook holes at the corners of the wall mounting bracket to hang the industrial Ethernet injector on the wall.

Step 5. To remove the wall mount bracket, do the opposite from the steps above.

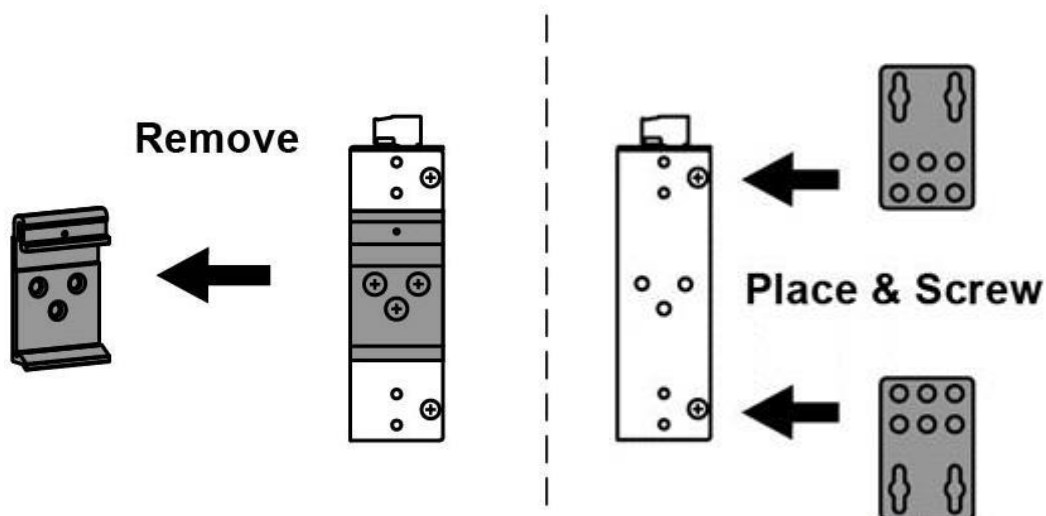

Figure 3.4: Remove DIN-Rail Bracket from the Injector and Install the Wall Mount Bracket

Below, in Figure 3.5 are the dimensions of the wall mounting bracket.

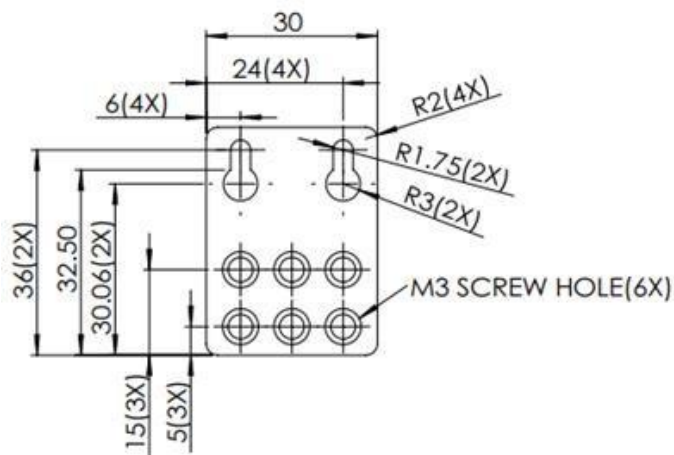

Figure 3.5: Wall Mounting Bracket Dimensions

# HARDWARE INSTALLATION

## Installation Steps

This section will explain how to install WINJ-0201-90W-T-T.

### Installation Steps

Step 1. Unpack the industrial Injector from the original packing box.

Step 2. Check if the DIN-Rail bracket is screwed on the industrial Injector.

- If the DIN-Rail is not screwed on the industrial Injector, please refer to the **DIN-Rail Mounting** section for DIN-Rail installation.
- If you want to wall mount the industrial Injector, please refer to the **Wall Mounting** section for wall mounting installation.

Step 3. To hang the industrial Injector on a DIN-Rail or wall, please refer to the **Mounting Installation** section.

Step 4. Power on the industrial Injector and then the power LED light will turn on.

- If you need help on how to wire power, please refer to the **Wiring the Power Inputs** section.
- Please refer to the **LED Indicators** section for LED light indication.

Step 5. Prepare the twisted-pair, straight-through category 5 cable for Ethernet connection.

Step 6. Insert one side of the RJ-45 cable into Injector's Ethernet port and on the other side into the networking device's Ethernet port, e.g. switch, PC or server. The Ethernet port's (RJ-45) LED on the industrial Injector will turn on when the cable is connected to the networking device.

- Please refer to the **LED Indicators** section for LED light indication.

Step 7. When all connections are set and the LED lights all show normal, the installation is complete.



**Caution:** If the equipment is used in a manner not specified by the manufacturer, the protection provided by the equipment may be impaired.



**Attention:** Si l'équipement est utilisé d'une manière non spécifiée par le fabricant, la protection fournie par l'équipement peut être altérée.



**Caution:** The installation that the safety to any system incorporating the equipment is the responsibility of the assembler of the system.



**Attention:** L'installation que la sécurité de tout système intégrant l'équipement est de la responsabilité de l'assembleur du système.



**Caution:** This is an OPEN TYPE module and should be installed in a final safety enclosure characteristic.



**Attention:** Il s'agit d'un module de TYPE OUVERT et doit être installé dans une caractéristique finale d'enceinte de sécurité.



**Caution:** This device is intended for use indoor and at altitudes up to 2000 meters.



**Attention:** Cet appareil est destiné à être utilisé en intérieur et à des altitudes allant jusqu'à 2000 mètres.



**Caution:** Ambient Relative Humidity should be within the range of 5 and 95% (non-condensing).



**Attention:** L'humidité relative ambiante doit être comprise entre 5 et 95% (sans condensation).

**Note:** Clean the device with soft cloth with dry or water.



## TROUBLE SHOOTING

- Verify you have the right power cord or adapter. Never use a power supply or adapter with a non-compliant DC output voltage or it will burn the equipment.
- Diagnosing LED Indicators: To assist in identifying problems, the Injector can be easily monitored with the LED indicators which help to identify if any problems exist.
  - ◆ Please refer to the LED Indicators section for LED light indication.
- If the power indicator LED does not turn on when the power cord is plugged in, the user may have a problem with the power cord. Check for loose power connections, power losses or surges at the power outlet.
  - ◆ Please contact Wavesys Global for technical support service, if the problem still cannot be resolved.
- If the industrial Injector LED indicators are normal and the connected cables are correct but the packets still cannot transmit, please check the system's Ethernet devices' configuration or status.